

## Perform Guard No. 6006

**Subject:** SIPs

**Date:** January 2008 (Revised January 2019)

PowerFoam has developed a treatment called Perform Guard® for molded polystyrene which creates a termite resistant product.

Through this development, PowerFoam has conducted numerous studies on the efficacy of termite resistant PowerFoam insulation with Perform Guard.

### PowerFoam insulation with Perform Guard Testing Summary

Borates have been widely utilized by the scientific and pest control communities to resist termites. Numerous studies have been completed by universities, government sponsored agencies and industries showing the efficacy of borates for termites. Due to the effectiveness of the borates and their low toxicity to humans and animals, PowerFoam elected to research the compatibility of borates with molded polystyrene insulation products. PowerFoam insulation with Perform Guard is the result of the PowerFoam research and development effort.

Studies have been conducted to determine the resistance of products produced with PowerFoam with Perform Guard to several species of termites. These studies include force feeding and long-term full exposure. Summaries of each test completed are described. The results of the PowerFoam with Perform Guard test program demonstrate resistance to termites in the environments where these types of products will be utilized.

### 1. Termite Resistant Testing

**A.)** "Feeding and Survival of Subterranean Termites After Exposure to Untreated and Borate Treated PowerFoam Building Panels in Laboration, Gulfport, Mississippi, by Lonnie H. Williams, Principal Entomologist, November 1991.

The testing was initiated to evaluate the termite resistance of untreated panels and PowerFoam SIPs (Structural Insulated Panels) which utilized PowerFoam with Perform Guard cores and topically treated OSB skins. Panel segments measuring 6" x 6" were extracted from full size panels and were exposed to both *Reticulitermes flavipes* (Kollar) and *Coptotermes*

*formosanus* Shiraki. A 6" x 6" sample panel was placed in a large vessel on top of a sterilized brick, which was placed in a moistened substrate. To each vessel, several thousand termites from a single colony were added. Each of the repetitions consisted of vessels with treated panel and untreated panel segments.

### Purpose:

To determine the efficacy of a treatment for SIPs which contain PowerFoam with Perform Guard and topically treated OSB skins.

### Results:

PowerFoam SIPs produced with borate treated insulation (Perform Guard) and topically treated skins were protected from severe feeding damage by the native species (*Reticulitermes flavipes*) and the introduced species (*Coptotermes formosanus*) of termites. The treated panels using PowerFoam with Perform Guard had complete kill of the *Reticulitermes flavipes* in 1 week and the *Coptotermes formosanus* workers in 6 weeks while the untreated panels had over 80% survival rates for both species after 6 weeks and exhibited severe panel damage by the termites.

It was also found that PowerFoam with Perform Guard cores laminated to plain OSB (no topical treatment) reduced weight loss and foraging tube construction as compared to the completely untreated samples.

### 2. Insitu-Testing

**A.)** "Evaluation of Structures Constructed with Borate-Treated Components for Protection from Damage by Insects and Decay Fungi" conducted by the United States Department of Agriculture, Lonnie Williams, Principal Entomologist, and William H. Sites, Plant Pathologist.

Three structures erected utilizing PowerFoam SIPs made with PowerFoam with Perform Guard cores were built by the USDA to monitor borate treated construction component resistance

to damage by wood damaging subterranean and drywood termites and decay fungi. The first structure was erected in November of 1991, at the Forest Sciences Laboratories in Gulfport, Mississippi. The second structure was built in January 1992 in a park in Jacksonville, North Carolina, and the third structure was built November 1993 in the Oregon State University Research Forest, Corvallis, Oregon.

**Purpose:**

To conduct a long-term insitu exposure and monitor the resistance of PowerFoam SIPs produced with PowerFoam with Perform Guard.

**Results:**

None of the treated structures have termite damage. Non-treated structures built on the sites exhibited termite activity.



[www.powerfoam.com](http://www.powerfoam.com)



550 Murrary Street  
Midlothian, TX 76065

Office: 800-883-3626  
Fax: 972-775-1806

## Perform Guard No. 6007

**Subject:** Foam Material Properties

**Date:** January 2008 (Revised January 2019)

PowerFoam has developed a proprietary treatment for Molded Polystyrene which makes it resistant to termites. The product is PowerFoam with Perform Guard®. Testing has been done both in the laboratory and field.

In addition to field and laboratory exposure tests, PowerFoam has conducted plant processing procedures, physical property testing, and coordinated system compatibility studies.

### Processing Procedures

PowerFoam, in cooperative work with its licensed facilities, has developed the processing techniques for the manufacture of Perform Guard product that meets or exceeds the requirements of ASTM C578, "Standard Specification For Rigid, Cellular Polystyrene Thermal Insulations".

### Physical Tests

Underwriters Laboratories has evaluated PowerFoam with Perform Guard for physical performance under appropriate ASTM Standards. Flexural Testing (ASTM C203) of Perform Guard showed strengths equal to or greater than minimum standards. Compressive Testing (ASTM C165) showed strengths equal to or greater than minimum standards. Density Testing (ASTM C303) showed densities equal to or greater than minimum standards. Perform Guard is a listed UL material.

### In-Plant Testing

The Quality Assurance procedures of PowerFoam's Third Party Quality Control Program call for in-plant testing of each lot of material. PowerFoam had testing Perform Guard under the guidelines of UL QC Program. These tests qualify daily production runs of PowerFoam with Perform Guard to the critical standards of ASTM C578.

### Fire Performance

PowerFoam submitted PowerFoam with Perform Guard samples to Underwriters Laboratories for fire evaluation. UL 723 "Test for Surface Burning Characteristics of Building Material" tests (also known as ASTM E84) were run. The results showed that PowerFoam with Perform Guard has a similar flame spread and smoke developed rating, when compared to industry standard. Addition full scale testing conducted on systems, such as PowerFoam Structural Insulated Panels, using PowerFoam with Perform Guard, demonstrated passing fire performance.

### Systems Compatibility

Compatibility studies by various adhesive manufacturers and independent laboratories have shown that adhesive laminations using Perform Guard do not differ from untreated molded polystyrene foam. Corrosion testing, using the Kesternich Cabinet procedure, has shown no corrosion to metal.

Note: PowerFoam with Perform Guard has been tested against termites. A list of specific species on file. PowerFoam with Perform Guard is not a barrier system, but should be used as a component in a total insect management program.



[www.powerfoam.com](http://www.powerfoam.com)

## Perform Guard No. 6008

**Subject:** How it Works

**Date:** January 2008 (Revised January 2019)

PowerFoam with Perform Guard® is molded polystyrene which is treated to resist termites. This product is produced by incorporating a naturally mined mineral into PowerFoam with Perform Guard product. However, many individuals ask “How does it work?” and “Why is it effective?”.

Basically, PowerFoam with Perform Guard is designed to resist termites from creating a community within the insulation. It is also designed to limit tunneling through the PowerFoam with Perform Guard material for extended periods. The borate derivative contained within the PowerFoam with Perform Guard acts as a bacterial agent against the gut fauna that break down cellulose in termites. For the borate derivative to act effectively, the termites must ingest it or at a minimum, masticate (chew) the PowerFoam with Perform Guard. Therefore, there may be some minor excavating of the PowerFoam with Perform Guard.

The termites must come in contact with the material before they can determine that the material is treated. When this occurs, two scenarios follow: The termite may continue to excavate the material for some time, then succumb to the deleterious effects of the borate material... or the termite will elect to move away from the inhospitable environment presented by the PowerFoam with Perform Guard.

PowerFoam with Perform Guard is not a repellent, nor is it a contact insecticide. Through the life of the PowerFoam with Perform Guard it is probable that the material will be visited from time to time. However, the borate additive prevents continued attacks and helps to retain the insulation's serviceability.

Note: PowerFoam with Perform Guard has been tested against termites. A list of specific species on file. PowerFoam with Perform Guard is not a barrier system, but should be used as a component in a total insect management program. Insects may enter in through other access areas.



[www.powerfoam.com](http://www.powerfoam.com)

## Perform Guard No. 6009

**Subject: Testing for mold Resistance**

**Date: January 2008 (Revised January 2019)**

PowerFoam with Perform Guard® was subjected to accelerated moisture/mold exposure testing to gauge its degree of mold resistance. Testing was based upon ASTM D3273-00, "Standard Test Method for Resistance to Growth of Mold on the Surface of Interior Coatings in an Environmental Chamber." This testing involves exposing the PowerFoam with Perform Guard to mold in an high humidity environment, approximately 90% RH. In addition to the testing of

PowerFoam with Perform Guard sample, samples of southern yellow pine were tested as a control. At the end of the 3 month test, the growth of mold (Trichoderma and Aspergillus) was obvious on the southern yellow pine. NO mold growth was present on the PowerFoam with Perform Guard. Please also refer to Technical Bulletin PowerFoam MPS no. 1004.



**Southern Yellow Pine  
with Mold Growth**

**PowerFoam with NO  
Mold Growth**



[www.powerfoam.com](http://www.powerfoam.com)

## Perform Guard No. 6010

**Subject:** Field Testing

**Date:** January 2008 (Revised January 2019)

PowerFoam with Perform Guard® termite resistant molded polystyrene is recognized in code evaluation reports for below grade applications in regions of very heavy termite pressure. PowerFoam with Perform Guard received this recognition through extensive below grade in-situ testing over a period of 5 years at three termite testing locations in the southern U.S. This bulletin provides a brief description of the testing along with pictures of the test results.

Three test plots were selected for the evaluation of PowerFoam with Perform Guard. The test plots were located in Georgia and Mississippi. These plots are within the region defined as very heavy termite pressure by the model building codes. PowerFoam contracted with a third party testing firm, Rich Mountain, to conduct all testing and report all test results.

The testing was conducted following a test method developed jointly by Rich Mountain and PowerFoam. The test method was modeled after AWPA E-7-93, "Standard Method Of Evaluating Wood Preservatives By Field Tests With Stakes." The testing consisted of samples adhered with construction adhesives/sealants to a concrete block. This geometry was selected to mirror below grade insulation of concrete/masonry walls. The detailed test method is available from PowerFoam upon request.

The samples geometry was such that the samples were installed adjacent to below grade bait wood. This was intended to accelerate the exposure to termites by providing an large initial food source for the termites. A second piece of bait wood was installed above the sample to evaluate the extent that termites would excavate and tunnel through the insulation.

Attached to this bulletin are pictures from our testing. These include the sample fixture geometry, test plots, and cross sections of excavated samples.

The performance of the PowerFoam with Perform Guard sample is quite dramatic when compared to untreated insulation. Untreated insulations shows very obvious damage resulting from extensive excavation and tunneling. In contrast, PowerFoam with Perform Guard shows very little damage.

The extensive testing conducted on PowerFoam with Perform Guard has led to Perform Guard being the only rigid foam recognized for application in areas of heavy termite pressure.

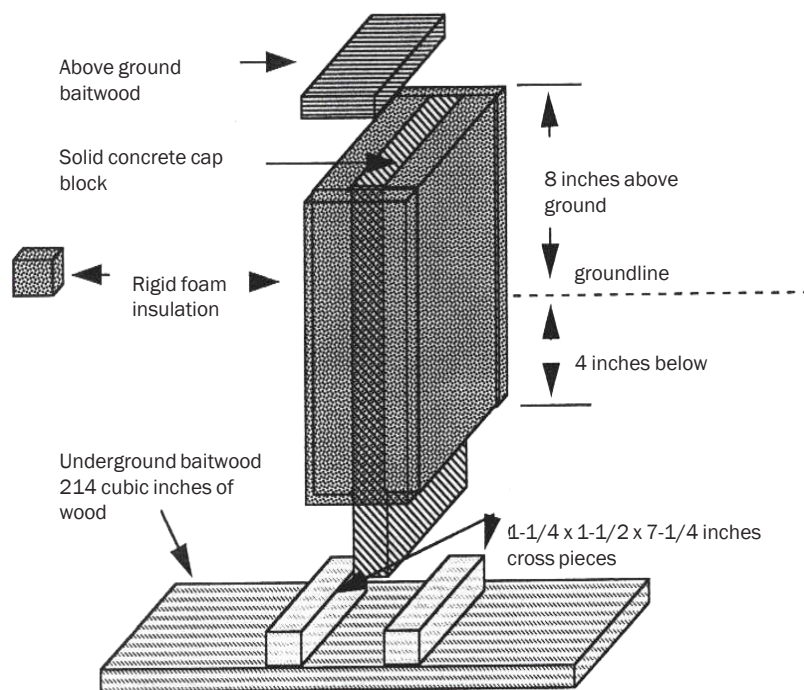

**TEST FIXTURE - replicates below ground applications.**



**TEST FIXTURE - Prior to installation showing underground baitwood base to attract termites to site. Canister cover to protect termite activity.**



**Field installation of test textures - Stone County, Mississippi.**



**Field installation of test textures - Griffin, Georgia.**





**#45 TEST FIXTURE - Examination of of non-treated EPS after 3 years exposure.  
Highland Site, Mississippi.**



**#45 TEST FIXTURE - cut open to reveal extensive termite damage.**



**#45 TEST FIXTURE - Close-up shows extensive termite damage.**



**#45 TEST FIXTURE - Close-up shows active termites.**



**#45 TEST FIXTURE - Close-up shows nesting infestation of termites.**



**#45 TEST FIXTURE - Close-up shows termite nesting galleries formed in non-treated EPS.**



**#64 TEST FIXTURE - Examination of PowerFoam with Perform Guard after 3 years exposure. Highland site, Mississippi.**



**#64 TEST FIXTURE - cut open to reveal limited termite damage.**



**#64 TEST FIXTURE - Close-up shows no termite damage.**



**#64 TEST FIXTURE - Close-up shows slight termite damage.**



**#64 TEST FIXTURE -  
PowerFoam with Perform  
Guard and R-Control  
Do-All-Ply.**

**#45 Test Fixture -  
Non-Treated MPS and standard  
construction adhesives.**



**#64 and #45 TEST FIXTURES - Close-up comparison.**



[www.powerfoam.com](http://www.powerfoam.com)



550 Murrery Street  
Midlothian, TX 76065

Office: 800-883-3626  
Fax: 972-775-1806

## Perform Guard No. 6011

**Subject:** Building Code Compliance

**Date:** January 2008 (Revised January 2019)

PowerFoam with Perform Guard® termite resistant molded polystyrene is recognized in PowerFoam building code evaluation reports for below grade applications in regions of very heavy termite pressure. This bulletin provides a description of the testing required by the International Code Council Evaluation Service (ICC ES) to achieve this recognition.

The ICC ES requirements to recognize a foam plastic insulation as termite resistant are detailed in the "EVALUATION GUIDELINE FOR TERMITE-RESISTANT FOAM PLASTICS," also known as AC 239. A summary of the testing requirements of AC239 are as follows:

- Testing shall be in accordance with AWPA E-7, "Standard Method of Evaluating Wood Preservatives by Field Tests with Stakes", modified to suit the intended application of the termite-resistant foam plastic.
- Testing shall be representative of the final installed product.
- Test assemblies shall be exposed to a minimum of three termite test plots.
- Minimum of five replicates for each assembly type per test plot.
- Assemblies shall be arranged in a randomized complete block design within the plots.

The assemblies are inspected annually along with wood monitoring stakes to ensure that the plots are providing sufficient and uniform exposure to termites. After 36 months of exposure, the test assemblies are destructively evaluated for termite damage. After the 36 months of exposure, the termite-resistant foam plastic shall have no more than 5 percent damage. Control or non treated samples shall also be evaluated to confirm termite damage.

The development of AC239 was in response to language in the model codes. For example, Section 320.5 of the 2006 International Residential Code (IRC) states: "In areas where the probability of termite infestation is "very heavy" ... extruded and expanded polystyrene, polyisocyanurate and other foam plastics shall not be installed on the exterior face or under interior or exterior foundation walls or slab foundation located below grade."

Thus, the use of foam plastics is restricted from use in areas of "very heavy" termite exposure. However, included in the IRC is language for exceptions to the restriction. Specifically, exception 2 states that: "When in addition to the requirements of R320.1, an approved method of protecting the foam plastic and structure from subterranean termite damage is provided."

PowerFoam with Perform Guard has been evaluated by the ICC ES in accordance with AC239 under exception 2 of section R320.1 of the IRC. As a result, PowerFoam with Perform Guard has been recognized in the ICC-ES evaluation report, ESR-1006. ESR-1006 section 4.5 provides for the special use of PowerFoam with Perform Guard in wood construction in areas of very heavy termite infestation. The evaluation report language of section 4.5 is "PowerFoam with Perform Guard boards are termite-resistant and are not restricted under Section R320.5 of the IRC or Section 2603.8 of the IBC."

Subsequently, PowerFoam with Perform Guard may be used in regions of "very heavy" termite exposure.

The PowerFoam with Perform Guard treatment is for the protection of the insulation integrity and does not provide protection for the structure. A pest control operator should be contacted for protection of the structure in accordance with the IRC or IBC. Methods of protection may be chemical soil treatment, pressure preservative treated wood, naturally termite resistant wood, physical barriers, or any combination of these methods.



[www.powerfoam.com](http://www.powerfoam.com)

## Perform Guard No. 6012

**Subject:** Testing Update

**Date:** January 2008 (Revised January 2019)

PowerFoam developed a full scale research program in the 1990's to determine the effectiveness of PowerFoam with Perform Guard® when exposed to termites.

Some historical research had been previously conducted on foam plastic insulation but these were small scale laboratory tests and could not be anticipated to match performance in real world applications. Small scale laboratory tests do not replicate the below grade installation geometry of insulation nor do they typically provide the necessary time exposure of field installations.

Other research has also been published on borate treated expanded polystyrene, but these are either at dosage levels not commensurate with PowerFoam with Perform Guard or do not meet the requirements of the International Code Council Evaluation Service (ICC ES) for termite resistant foam plastics (Evaluation Guide 239). The requirements of the ICC ES evaluation guide include:

- Testing shall be conducted for at least 3 years
- Testing shall be in accordance with AWPA E-7, "Standard Method of Evaluating Wood Preservatives by Field Tests with Stakes", modified to suit the intended application of the termite resistant foam plastic.
- Testing shall be representative of the final installed product.
- Test assemblies shall be exposed to a minimum of three termite test plots.
- Minimum of five replicates for each assembly type per test plot.

Based upon these requirements, the PowerFoam program was developed to ensure that the test data was not limited to a laboratory testing, but instead a full scale test program of samples installed in heavy termite regions of the U.S. PowerFoam contracted with a third party researcher to conduct the testing. The testing consisted of evaluating PowerFoam with Perform Guard at three test sites.

One test site was located in the USDA research forest in Athens, Georgia. Two additional test sites were located near Gulfport, MS. At each test site, a minimum of 10 samples of PowerFoam with Perform Guard were evaluated. PowerFoam worked to ensure that the testing fully complied with ICC ES Evaluation Guide 239.

Upon completion of the test program, PowerFoam submitted the complete test data to ICC ES for evaluation. ICC ES has subsequently published Evaluation Service Report (ESR) number ESR-1006 which includes recognition of PowerFoam with Perform Guard as a termite resistant insulation.

A summary of the third party research data from the PowerFoam program was submitted to the peer reviewed Forest Products Journal for publication. The paper met the stringent requirements of peer review and has been published in the March 2005 issue of the Forest Products Journal. A copy of the article is attached to this technical bulletin.

The attached test were conducted under severe exposure conditions that are intended to exceed actual exposure conditions. Regardless of application area, PowerFoam with Perform Guard should be installed following the PowerFoam with Perform Guard below grade Application Guide.



[www.powerfoam.com](http://www.powerfoam.com)



# Boron-treated expanded polystyrene insulation resists native subterranean termite damage after 3-year field exposure

Lonnie H. Williams\*  
Todd B. Bergstrom

---

## Abstract

Foam plastic insulation around or beneath building foundations can provide hidden entryways that must be considered for effective termite prevention. Borate-treated expanded polystyrene (EPS) rigid foam insulation installed with construction sealant (CS) to a concrete block was evaluated for resistance to damage by native subterranean termites. The evaluation included 3-year exposure to termite attack in three widely separated test plots of insulation-enclosed concrete test units partially buried in soil, with untreated wood above and below the units to attract termites. By digital image analyses, the percentage of termite damage was quantified by treatment for field-exposed EPS samples to provide data amenable to statistical analyses. Borate-treated EPS with borate-treated CS had 3.2 percent damage compared to 23.9 percent for untreated EPS installed with untreated CS after 3-year field exposure.

---

In 1992, the Model Energy Code began to mandate use of insulation on and beneath building foundations to enhance energy savings (CABO 1992). This use of insulation soon became commonplace in the southeastern United States, which is a high-risk region for subterranean termite attack. This led to a rise in termite damage related to the use of insulation (Smith and Zungoli 1995a, 1995b). The National Pest Management Association warned its member companies to regard all untreated insulation the same as untreated wood in contact with the ground (Kramer 1993).

Termites can tunnel through insulation and/or the interface between insulation and the foundation. Insulation enclosing entire masonry or concrete foundations (below ground and covered by coatings such as synthetic stucco) pro-

vides termite entryways that cannot be detected by inspection. Therefore, personnel with responsibility for effective termite protection in many states provide guidelines that require a 6-inch (150-mm) wide gap (inspection band) in insulation around the perimeter of foundations and have restricted its use below ground.

This study evaluates expanded polystyrene (EPS) rigid foam insulation installed in conjunction with construction sealant (CS). Combinations of borate-treated EPS and CS were evaluated along

with untreated materials (Table 1). The borate-treated EPS is manufactured under a patented process (Savoy 1993) using disodium octaborate tetrahydrate (DOT). The product is marketed under the brand name Perform Guard®.

Although small-scale laboratory experiments may be suitable for evaluating contact pesticides, a field test method was developed to evaluate the performance of a borate treatment chemical. Borate chemicals are slow-acting toxicants and limited initial damage was expected to occur due to preliminary termite exploration. Small-scale laboratory tests were not anticipated to be reliable predictors of the field performance of borate-treated EPS. Test units were designed that simulated use of rigid board insulation and CS around building foundations. Testing procedures were modeled after the American Wood Preservers' Association Standard E7-93 for evaluating candidate wood preservatives by field tests (AWPA 2000).

This paper describes the termite damage following 3 years of field exposure of untreated and treated EPS test units and the results of digital image analyses of EPS samples after in-ground exposure to termite attack.

---

The authors are, respectively, President, Rich Mountain Wood Protection Services, Inc., 14936 Angela Dr., Gulfport, MS 39503; and Technical Director, AFM Corp., 211 River Ridge Circle, #102, Burnsville, MN 55337. This paper was received for publication in September 2003. Article No. 9747.

\*Forest Products Society Member.

©Forest Products Society 2005.

Forest Prod. J. 55(3):56-60.

Table 1. — Results of analysis of variance tests for annual inspection data by plot and year.

Plot no.	Variable	Year	Sig. <sup>a</sup>	p-value	Means comparison test differences (LSD) <sup>b</sup>
1	Stake	1997	No	$p \leq 0.1795$	Treatment 1 with 2
1	Baitwood	1997	No		
1	Hole counts	1997	No		
2	Stake	1997	No		
2	Baitwood	1997	Yes	$p \leq 0.0001$	Treatment 1 with 2, 3, 4
2	Hole counts	1997	Yes	$p \leq 0.0001$	Treatment 1 with 2, 3, 4
3	Stake	1997	No		
3	Baitwood	1997	Yes	$p \leq 0.0340$	Treatment 1 with 2, 3
3	Hole counts	1997	Yes	$p \leq 0.0007$	Treatment 1 with 2, 3, 4

<sup>a</sup> Yes means significant differences exist, no means they do not.

<sup>b</sup> Treatments: 1 = untreated EPS/untreated CS; 2 = untreated EPS/treated CS; 3 = treated EPS/treated CS; 4 = treated EPS/untreated CS.

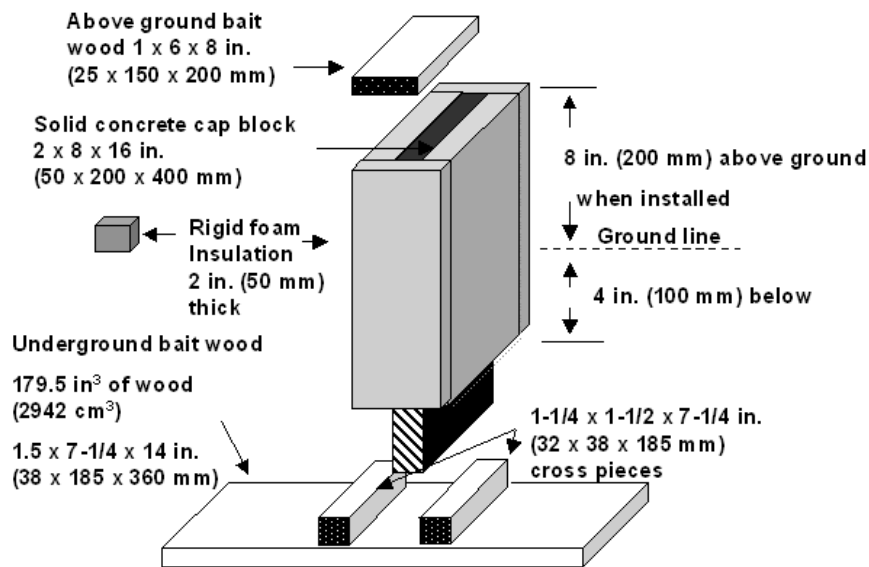

Figure 1. — Schematic showing construction and installation details of test unit used to field test rigid foam insulation with untreated aboveground and below-ground baitwood pieces to attract termites. Each insulation piece was bonded to concrete or insulation with a continuous layer of untreated or borate-treated construction sealant.

## Materials and methods

### Field tests

**Treatments.** — Test treatment combinations were: 1) EPS insulation board bonded to concrete with construction sealant (CS); 2) EPS insulation bonded to concrete with DOT-treated CS; 3) DOT-treated EPS insulation, as AFM Corporation's Perform Guard®, bonded to concrete with DOT-treated CS; and 4) DOT-treated EPS insulation bonded to concrete with untreated CS. All insulation was 2 inches (50 mm) thick.

**Test units.** — A test unit was a solid concrete cap block with 12 inches (300 mm) of EPS bonded flush with one end of the block on all four surfaces by a continuous layer of either treated or untreated CS. **Figure 1** shows the components and how a unit was installed. Installation was completed by an opaque plastic cover that provided protection from weather and the dark conditions that termites prefer for tunneling activities. A 3/8-inch- (10-mm-) diameter hole in each narrow face provided ventilation to reduce condensate moisture. A southern pine sapwood stake, 3/4 by 1-1/2 by

18 inches long (19 by 38 by 460 mm), was driven in the ground to half its length adjacent to each unit for monitoring termite activity during testing.

Untreated wood was placed underground as an attractant for termites as may occur from buried wood at building sites. The aboveground baitwood could be attacked only via tubes built over or through insulation or the insulation/sealant interface. This test design simulated what termites must do to attack wood in buildings above solid concrete foundation walls insulated with rigid board insulation.

**Test plots.** — Ten replicates of each treatment were tested in each of three widely geographically separated plots to ensure exposure to different colonies and populations of termites. To offset the possibility that the boron treatments may affect termite populations like a toxic bait, all test units were randomly assigned to evenly spaced points on a grid consisting of five columns and eight rows, with 10-foot (3-m) spacing between points. Plots 1 and 2 were located in southern Mississippi, Harrison County and Stone County, respectively. Plot 3 was located on University of Georgia Experiment Station property near Griffin, Georgia.

**Annual inspection procedures.** — During the fall of 1995 through 1997, each monitoring stake adjacent to the test unit was pulled and visually graded for termite damage. Grading was done essentially as described by the American Wood Preservers' Association Standard E7-93 (2000) wherein a grade of 10 meant no damage ranging through moderate damage at grades 7 or 6 to severe damage at 4 and failure at 0. Stakes graded below 9 for termite attack and stakes with extensive decay, but no termite attack were replaced at each inspection.

Termite attack to the baitwood above the test units was graded by the same system. Each baitwood piece graded below 10 was replaced by a new piece. Ways that termites constructed tubes to reach the baitwood were recorded, such as over the exterior or through insulation or at the insulation/sealant interface. Tunnel openings (holes) in each unit's top surfaces were counted. These counts suggested that untreated insulation had severe, continuing damage. Termites also made initial explorations into treated units, but this activity did not appear to be continuing. Digital image analysis of the

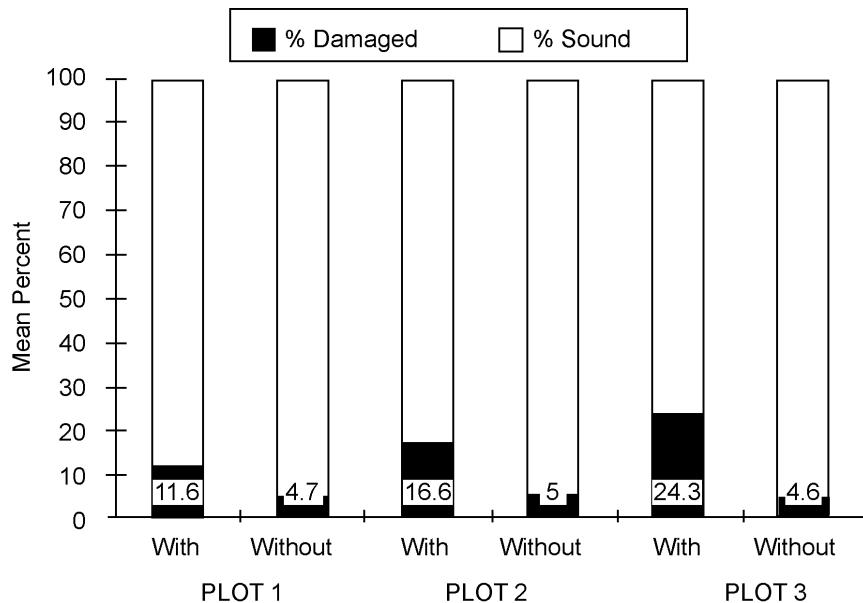

Figure 2. — Mean percent sound and damaged expanded polystyrene in samples with and without visible termite damage from each of three plots when images were analyzed following 3 years of field exposure.

interior of the insulation was chosen as a method to quantify differences in termite damage by treatment and to provide data amenable to statistical analyses.

#### Digital image analyses

*Selection of sampled units.* — After the 1997 fall inspection, the five most heavily damaged units/treatment were selected, based on hole counts and baitwood ratings from the 1995-1996 inspections (20 units/plot, total 60 units).

*EPS sampling procedures.* — Samples of EPS were cut with a hot-wire cutter. First, a cut was made through each EPS piece to the concrete about 3 inches (75 mm) below the top surface of the test unit. EPS was cut at approximately 1/2-inch (12 mm) from the concrete because CS and soil-filled termite tunnels in untreated EPS prevented cutting any closer to the concrete. Twelve surfaces were labeled per unit: cross section of EPS 3 inches (75 mm) below top surface, top inside surface, and bottom inside for EPS removed from the north side of the unit and the same sequence of samples for the east, south, and west surfaces. The total number of EPS surfaces subjected to analyses was: 12 samples/unit  $\times$  5 units/treatment = 60 EPS surfaces/treatment  $\times$  4 treatments = 240/plot  $\times$  3 plots = 720 images after 3 years of field exposure.

*Image archiving.* — Hardware and software used for archiving images included: Kodak DC-120 Digital Science®

camera equipped with Pictureworks PhotoEnhancer® (PPE) image processing software, Media Cybernetic's Image-Pro Plus® (IPP) image analysis and Image Database (IDB) software, and a staging platform and background illuminated by incandescent bulbs in reflector-type sockets. Each image was cropped to remove the EPS/background interface that was predetermined to interfere with analysis and archived in TIF format via the Twain-compliant features of the IPP and PPE software. All images were photographed at the same focal distance.

*Image analysis.* — Each image was analyzed using the Hue-Saturation-Intensity color model and pseudo-color features of the IPP software. First, an intensity channel was extracted from the image and subjected to best-fit contrast enhancement. The enhanced image was then analyzed for its intensity content and allocated to 1 of 2 predetermined ranges: 0 to 110 which indicated termite-damaged EPS or 111 to 255 which indicated undamaged (sound) EPS. The IPP software calculated the area within each range and the percentage of the total image area that was either termite-damaged or sound. Before analysis, each cropped image was examined visually to assess whether damage was from termites or an apparent damage artifact resulting from CS and/or identification labels, which could not be automatically distinguished from termite damage.

*Image analysis data.* — The significance of treatment was determined by analysis of variance (ANOVA) tests performed separately by plot on percent termite damage data after arc sine transformation. The presence of significant differences was determined by Fishers Multiple Comparison tests.

## Results and discussion

### Field tests

Results of ANOVA tests with corresponding *p*-values show, by plot, when significantly different treatment effects occurred for stake or baitwood ratings and hole counts (Table 1). The results of means comparison tests show what treatments differed significantly from others. Mean stake ratings did not differ significantly by treatment for any plot. This implies that all treatments were subjected to relatively uniform termite activity during field exposure.

Results for all plots suggested that termite attack to wood above untreated EPS increased with time while attacks to wood above other treatments remained stable. Analyses of inspection data showed that wood above units with untreated EPS and untreated CS had significantly more damage than wood above units with borate-treated EPS and borate-treated CS. In general, treated EPS and treated CS offered the best protection.

Termites had also damaged boron-treated EPS and baitwood above it. Attack of baitwood above treated units apparently was declining with time while attack of baitwood above the untreated control was either increasing or was the greatest attack. Inspection data, however, did not reveal how much treated EPS was damaged nor how damage to EPS differed among treatments.

Image analyses offered a way of quantifying differences for statistical analyses to determine the effect of the treatments.

### Image analysis

*Characteristics.* — For 720 analyzed images, 375 had visible termite damage, 345 did not. Estimates of damage including apparent damage from CS and/or identification labels for the 375 samples ranged from 11.6 to 24.3 percent, by plot (Fig. 2). For the 345 images without visible termite damage, the mean ( $\pm$  standard deviation) estimated damage was  $4.8 \pm 1.8$  percent. This error factor

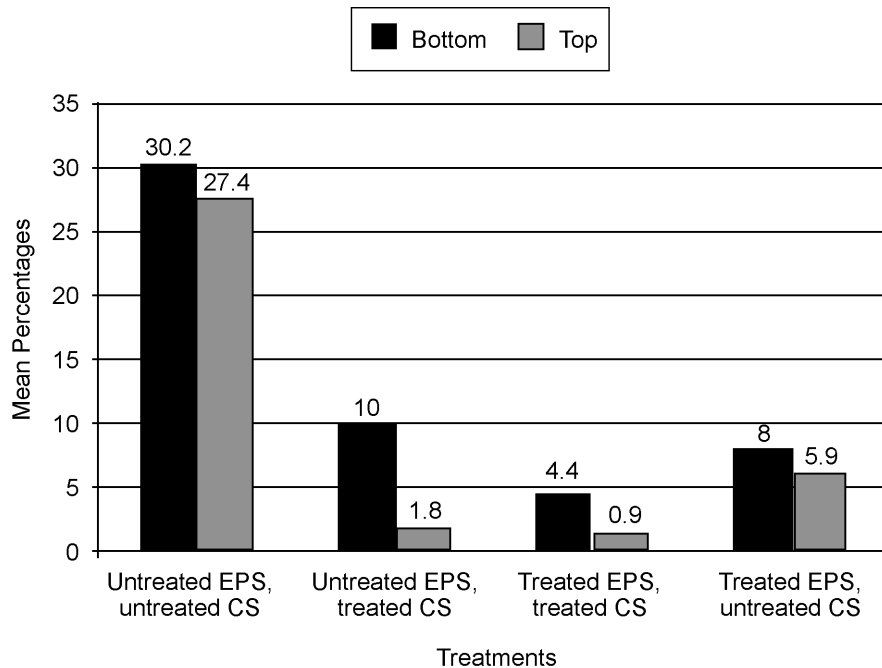

Figure 3. — Mean percentages of termite-damaged insulation per treatment for bottom and top samples of units in all plots after 3 years of field exposure ( $n = 60$ ). Means shown are after subtraction of an error factor associated with image analyses of 2.7 for bottom and 3.4 for top samples:  $n$  for error factors = 28 and 145, respectively.

associated with image analyses was essentially the same for each plot (Fig. 2).

**Results.** — In all three plots, results of ANOVA tests indicated that treatment was a highly significant factor ( $p \leq 0.001$ ) affecting the percentage of termite damage in EPS. Results of Multiple Comparison Tests (Fishers) indicated that the EPS for treatment 1 (untreated EPS and untreated CS) had significantly greater ( $p \leq 0.05$ ) termite damage than EPS for the remaining treatments.

Analysis was conducted to compare the damage to the top part of samples with that in the lower or bottom part of the sample. Damage to the top region would indicate significant tunneling throughout the EPS. Mean percentages of damage for all plots were always higher for bottom samples than top samples for all treatments (Fig. 3). This was true across all plots and in each plot. For untreated EPS and untreated CS, damage was 30.2 percent for top samples and 27.4 percent for bottom samples. However, damage was 0.9 percent for top samples and 4.4 percent for bottom samples from units with treated EPS and treated CS, indicating that termites were only making exploratory attacks at the bottom of treated EPS pieces adjacent to the large underground baitwood. When

only EPS or CS was treated, damage to top samples was from 8.0 to 10.0 percent and damage to bottom samples was from 1.8 to 5.9 percent (Fig. 3).

When cross-section samples were included and the error factor adjustment was made, the mean percentage of EPS damaged by termites was 3.2 percent for borate-treated EPS and borate-treated CS but 23.9 percent for samples with untreated EPS and CS. Means of termite damage for the remaining two treatments were 3.9 and 5.4 percent. Exposing insulation on all sides of a unit 4 inches (100 mm) below the groundline and just 2 inches (50 mm) above 179.5 in.<sup>3</sup> (2942 cm<sup>3</sup>) of untreated wood obviously was very severe exposure to subterranean termite attack (Fig. 1). Nevertheless, damage to borate-treated EPS with borate-treated CS remained a relatively minor 3.2 percent. A damage level of under 5 percent is considered acceptable by the International Code Council evaluation guideline for foam plastic insulation (ICC 2003).

## Conclusions

### Annual inspection data

Stake ratings did not differ significantly by treatment for any plot or year, which implies that all treatments were

subjected to uniform termite activity. Wood above test units with untreated EPS and untreated CS showed significantly greater damage than wood above units with one of the three other treatments. Damage to the top surfaces of EPS with untreated EPS and untreated CS showed significantly greater damage than EPS surfaces on units with one of the other treatments. Results suggest that termite damage to EPS and/or untreated wood above it can be reduced by DOT treatment of EPS insulation and CS.

### Image analysis data

The EPS on test units with untreated EPS and untreated CS had significantly ( $p = 0.01$ ) greater damage from termites than the EPS on units with the other three test treatments containing combinations of borate-treated EPS and/or CS. EPS protected by the treatment combination of borate-treated EPS and borate-treated CS sustained less termite damage than EPS protected only by treated EPS or treated CS. Image analyses offer a reasonably accurate procedure for quantifying termite damage in EPS. Termites caused 3.2 percent damage when EPS was protected by borate-treated EPS and borate-treated CS compared to 23.9 percent for EPS not protected by any treatment.

Borate-treated wood is known to be a slow-acting toxicant, allowing termites to cause minor damage to wood before they either are killed or stop their attacks. Unlike wood, EPS apparently provides no food value, but potential shelter for termites. However, boron must be ingested as termites tunnel through or build tubes over EPS or damage would not be deterred. Unlike previous small-scale laboratory testing, field testing confirmed that borate treatment of EPS offers good protection against termite damage.

### Literature cited

- American Wood Preservers' Association (AWPA). 2000. Standard method of testing wood preservatives by field tests with stakes. Standard E7-93. In: 2000 Book of Standards. AWWA, Granbury, TX. 12pp.
- Council of American Building Officials (CABO). 1992. Model energy code. CABO, Leesburg, VA. 87 pp.
- Kramer, R.D. 1993. Foam insulation and termites. Service Letter ESFC 055075, No. 1284. National Pest Control Assoc., Inc., Dunn Loring, VA. 3 pp.
- International Code Council (ICC). 2003. Evaluation guideline for termite-resistant foam plastics, EG239. ICC, Whittier, CA. 3 pp.

Savoy, T.L. 1993. Building material with protection from insects, molds, and fungi. U.S. Patent No. 5,194,323. U.S. Patent and Trademark Office, Washington, DC. 12 pp.

Smith, B.C. and P.A. Zungoli. 1995a. Termites in rigid board insulation: Part 1. Pest Control Technol. 23(10):68,69,72-74.

\_\_\_\_\_ and \_\_\_\_\_. 1995b. Termites in rigid board insulation: Part 2. Pest Control Technol. 23(11):56,65-66.